

PTFE Lined Ball Valves DIN



High Performance

The **heavy duty construction** meets the stringent requirements of chemical process industry.

Specially designed for **low torque, bubble tight shut-off** and **minimal pressure drop**.

Virtually **maintenance free** and give long time service due to their quality and simplicity of design.

Outstanding corrosion resistance and high degree of safety in various applications.



PTFE Properties

- Very high inertia, due to the presence of fluorine atoms, which, due to their compact structure, shield the carbon atoms of the polymer chain from potential chemical damages.
- It is insoluble in every solvent under 300°C.
- It has a wide range of working temperatures to a maximum temperature of 200°C.
- Extremely low adhesiveness, due to its reduced superficial tension
- Lowest friction coefficient amongst every other existing solid materials
- It is extremely hydrophobic and completely hydrolysis-proof (it is used as an anti-corrosive) barrier and it can hold its characteristics even after years of being in contact with fluids).
- Chemically pure and inert.
- Microbiologically resistant, it doesn't let bacteria and fungi proliferate
- Electrically insulating
- Non-flammable
- It holds up very well against atmospheric and environmental ageing, even when it faces high temperatures or when in contact with solvents, oils, oxidizing agents and UV rays.
- Good mechanical properties, especially when employed in presence of vibration or flexions.





Materials

Position	Description	DIN
1	Body 1	1.0619+PFA
2	Body 2	1.0619+PFA
3	Ball-stem	1.4470 + PFA
4	Seat	PTFE (Modified)
7	Stem packing	PTFE (Modified)
8	Gland packing	S.S.1.4401
9	Spring washer	S.S. AISI 301
11	Cover	S.S. 1.4401
13	Cover bolt	A4-70
16	Handle	A351 CF8M/WCC
17	Handle bolt	S.S. (316)/1.045(8.8)
22	Stop pin	S.S. AISI 316
41	Stud	A2-70
42	Nut	A2-70
165	Stem bearing	PTFE (modified)+FC
193	Packing Casing	PFA+AISI 316

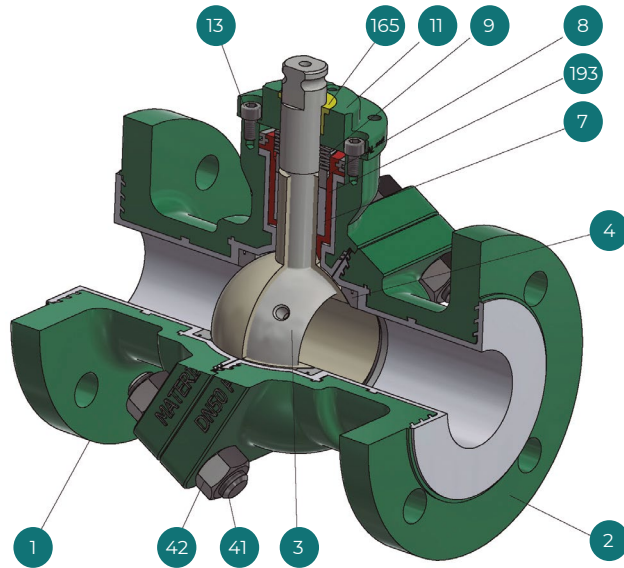

PFA thickness-minimum 3 mm

Range

PL 24 T

SIZE	RATING
DN15-150	PN16

Dimensions

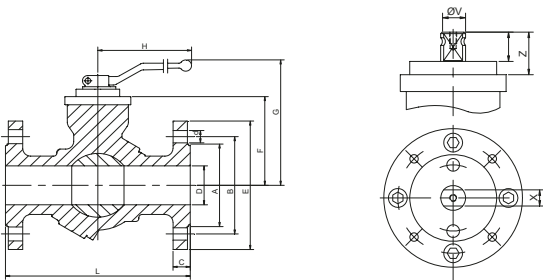

Pressure / Temperature

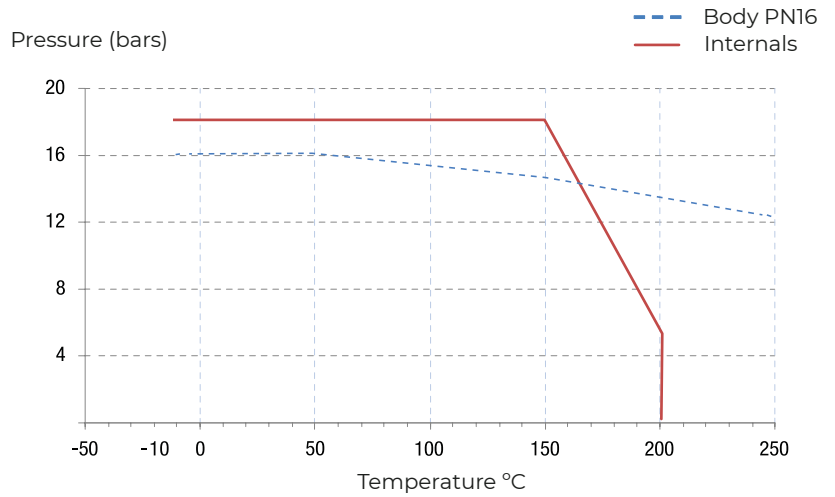

DN	PN	D	L	E	A	B	C	F	G	H	V	X	Y	Z	nxd	ISO5211	Torque	MAST	Weight
15	16	15	130	95	45	65	16	75	185	132	14	11	11	13,5	4 x 14	F05	8	82	3
25	16	25	160	115	68	85	18	88	185	145	18	14	17	19,5	4 x 14	F05	14	142	5
40	16	40	200	150	88	110	18	108	293	178	22	17	20	30	4 x 18	F07	31	338	9
50	16	50	230	165	102	125	18	114	293	184	22	17	20	30	4 x 18	F07	46	338	13
65	16	65	290	185	122	145	18	126	293	196	22	17	20	30	8 x 18	F07	55	338	20
80	16	80	310	200	138	160	20	128	450	222	28	22	22	40	8 x 18	F10	85	1070	26
100	16	100	350	220	158	180	20	142	450	236	28	22	22	40	8 x 18	F10	110	1070	34
150	16	150		285	212	240	22	188	740	297	36	27	35	50	8 x 22	F12	380	2199	68

**Depending on service conditions

*Torque values have been measured P at maximum rating at room temperature

*Dimensions are in mm. *Torque & MAST are in Nm * Weight in Kilograms





P+L VALVES

Who we are

P+L Valves is a new PTFE lined ball valve, as the result of the union of two major European manufacturers, LMP Fluorcarbon, a leading company specialized in the PTFE Lining field, and Pekos Valves, ball valve manufacturer with more than 30 years in the industry.



 **Synerkos**
Technical Valve Solutions

www.synerkos.com

Pekos Fabricación

 Bildosola industrialdea K3
48142 Artea,
Vizcaya, Spain

LMP Fluorcarbon

 Via Galileo Ferraris, 3
21020 Monvalle VA,
Italy